

E150-H	MAGNET HORN WITH HEATER (300 W) マグネットホーン ヒータ付	WHISTLE (Above 130 dB) 汽笛 (130 dB以上)	OUTLINE VIEW 外形図	MASS 質量 22 kg	
	1/3rd-OCTAVE BANDLEVEL オクターブバンドレベル	130 dB/1m	FUNDAMENTAL FREQUENCY 基本周波数	APPROX. 320 Hz	PROTECTION GRADE 保護等級
SOURCE 電源	DC24 V	CURRENT 電流	16 A	PAINTING 塗装色	WHITE/白 (MAKER STANDARD)

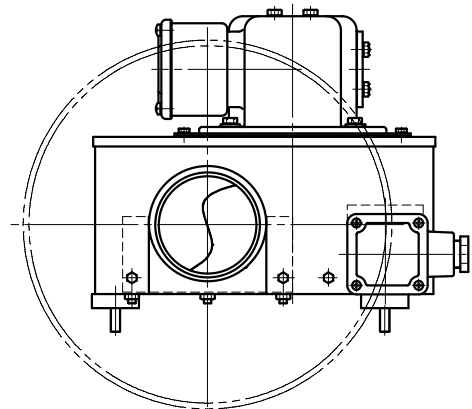
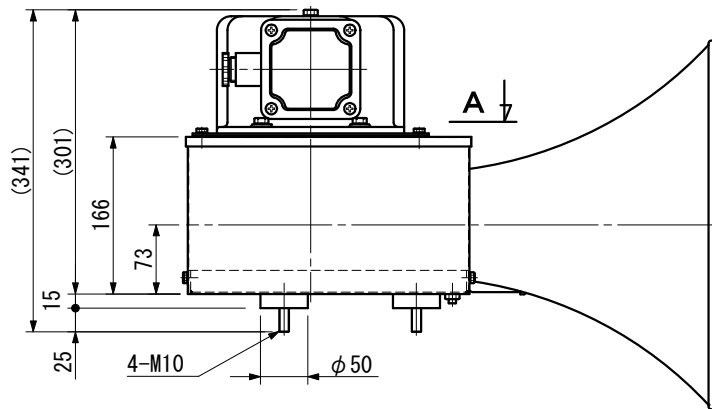
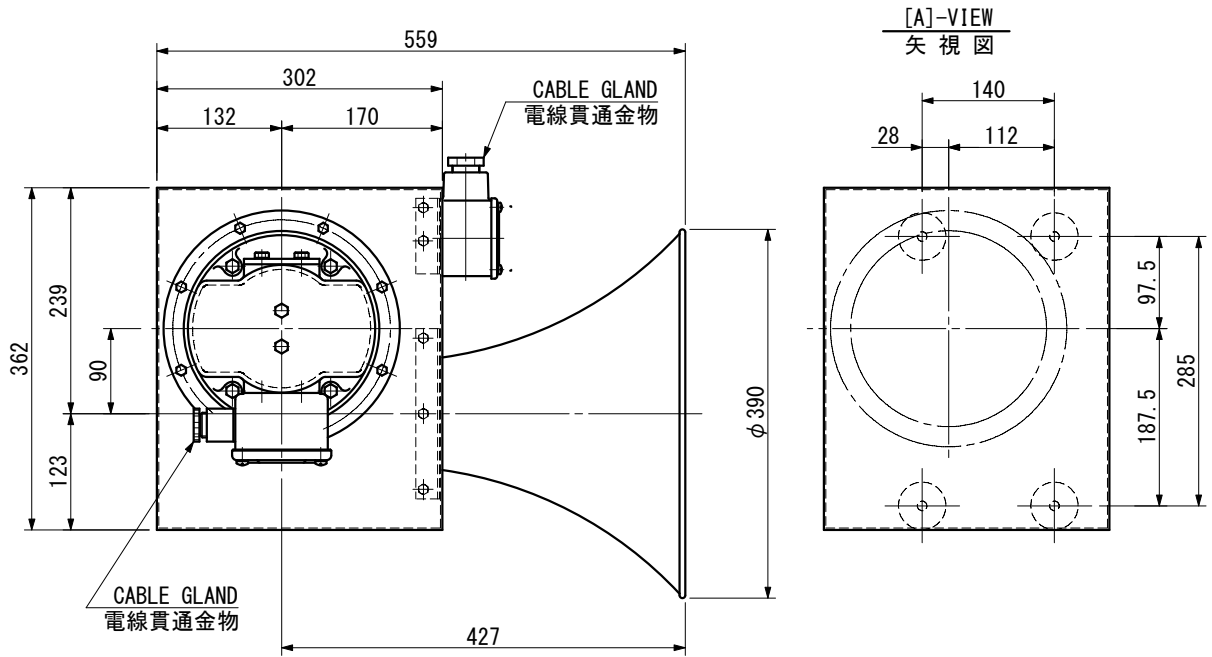

DATE	REV.	REMARKS	 IBUKI KOGYO CO. LTD. 伊吹工業株式会社	D. W. N.	N. Tanaka	DATE	FEB. -10. 2022
				C. K. D.	Y. Ueda	SCALE	1/8
				C. K. D.		DWG. NO	ibk-01030502